

# PROCENTEC



## ProfiHub A5

5 Channel DP Repeater

The well-known ProfiHub A5 is a robust network component for PROFIBUS DP installations. It allows long multi-device spur lines and backbone structures with star/tree segments in IP 65 applications. The ProfiHub A5 is essential to obtain better control during maintenance and upgrading of the network. The use of ProfiHub results in lower operational costs and the optimization of the entire production process.

The ProfiHub A5 is a perfect economic solution to create reliable star networks in RS 485 DP networks. It has the functionality of five galvanic isolated transparent repeaters. This allows network structures with extended spur lines that individually can handle a maximum of 31 devices and a length equal to the main bus. The ProfiHub A5 has the same functionality as the ProfiHub B5.



## Application areas

- Dynamic spur lines to actuators, flow meters and pH analyzers
- Star, tree and bus structured networks
- Removable drives and motors
- Outdoor applications with device and cable stress
- Roof mounted devices in tank farms
- Dirty and Humid environments
- Barrier for non-galvanic isolated equipment

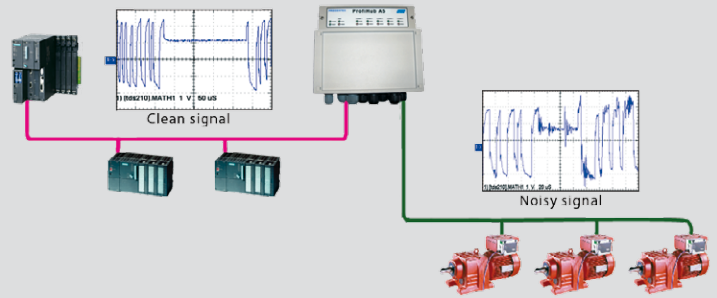

Example of the barrier function of the ProfiHub. Noise and EMC disturbances will not affect the backbone or the other channels

## Your benefits

- Hot slave insertion/removal during operation
- Short circuit protection on each channel
- Compact and robust construction
- On-board DB9 female connector for maintenance activities
- Suitable for all DP cables
- Conveniently arranged networks
- Extendable installations
- Cost saving

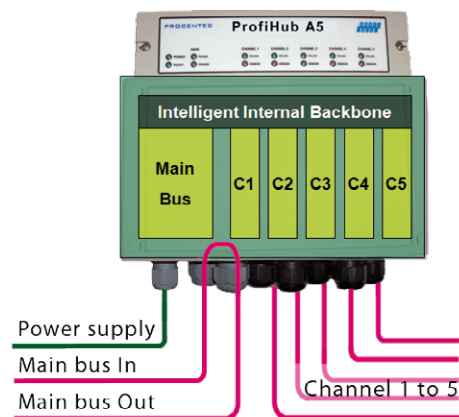

## Product features

- 5 Isolated repeater channels (6 segments)
- Transparent for all PROFIBUS DP protocols
- Suitable for PROFI-safe and MPI networks
- 31 devices per channel
- 9.6 Kbps - 12 Mbps
- Max. 1200 m segment length (depends on baudrate)
- Integrated termination facilities
- Configurable grounding system
- Glands or M12 connectors
- IP 65 classification

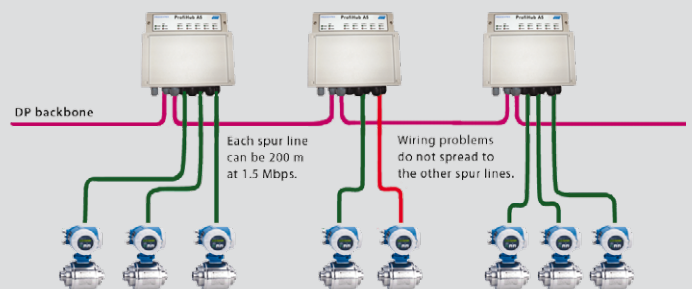

Example of dynamic spur lines to instruments. The devices can be added and removed during operation.

